

Review on High Efficiency, Low Cost Design of Solar Powered Electric Vehicle

Momin Shahbaz Akhter¹, Shaikh Sameer², Muqueem Khan³,
Shah Faisal⁴, Shaikh Shahbaz⁵

^{1, 2, 3, 4, 5}(Electrical Engineering Department, MMANTC/ Pune University, India)

Abstract: At present, solar powered vehicle is connected as one of the essential vitality sparing vehicle where the utilization of sustainable power source found practical vitality request with decline in fuel cost and purging of environment. One of the principle zones of sustainable power source assets today is solar power [1]. P.V cells are utilized to change over sunlight based vitality in to valuable electrical vitality. The target of this paper is to develop a productive sun oriented vehicle, with the goal that the one can travel regularly on a solid and affordable vehicle that essentially keeps running on free sustainable sun powered vitality This paper clarifies how the charge created by a variety of solar panel is gotten and its stream all through a battery bank is to be controlled utilizing a charge controller to ensure proficient putting away of in a battery pack. The put away vitality would be sustained to a BLDC motor which would run the vehicle. The mechanical development of the frame alongside all essential mechanical frameworks is shown. At last the wiring of the electrical framework on the mechanical body is illustrated.

Keywords: BLDC Motor, Lead Acid Battery, PWM chopper controller, Solar Panel

I. Introduction

A solar powered vehicle is utilized for land transport fueled by an electric motor, other vehicle has an overwhelming clamor and furthermore dirties the air, electric vehicle are smooth and quiet. A portion of the choices are sustainable power sources which incorporate all fuel types and vitality bearers, not the same as the fossil ones, for example, the sun, wind, tides, hydropower and biomass. Among these components, solar powered vitality is favored since it could give the cleanest supportable vitality to the longest term of time. On account of fuel issue, acquainting electric vehicle is with decrease the weight on fuel and our condition will be sufficient. The segments of an electric vehicle are BLDC motor, charge controller, Lead corrosive batteries, Battery Charger

Solar vehicles rely upon PV cells to change over daylight into power. Dissimilar to sun powered warm vitality which changes over sun oriented vitality to warm for either family purposes, modern purposes or to be changed over to power, PV cells straightforwardly convert daylight into power. Whenever daylight (photons) strikes PV cells, they energize electrons and enable them to stream, making an electrical flow. PV cells are made of semiconductor materials, for example, silicon and compounds of indium, gallium and nitrogen. Silicon is the most widely recognized material utilized and has a proficiency rate of 15-20% [2].

1.1 To Fight against Fuel Problem:

Sustainable power source originates from normal assets, for example, daylight, wind, tides, rain and geothermal warmth, which are altogether inexhaustible. These energies are gotten from common procedures that are reestablished continually. Electrical vitality is gotten from sunlight based, wind, sea, hydropower, biomass, geothermal assets, bio-powers and hydrogen. In the event that we can utilize sustainable power source to deliver control for electric Vehicle then it has no awful effect on our capacity deficiency issue and just as we diminish the weight on utilizing fuel.

1.2 Power is the Best as Renewable Energy:

Sun based vitality is the best vitality supply for electric vehicle in contrasting and other sustainable power source. Other wellspring of sustainable power source can't be utilized in electric vehicle. The body casing of the vehicle can be utilized as sun based plate from where the vehicle can get the complete power.

1.3 History of Solar Vehicles:

The primary blend of photovoltaic gadgets and electric vehicles occurred in the late 1970's. To create greater exposure and research enthusiasm for sunlight based fueled transportation, Hans Tholstrup composed a 3,000 km race over the Australian outback in 1987. Called the World Solar Challenge (WSC), contenders were welcomed from industry explore gatherings and best colleges around the world. General Motors (GM) won the

occasion by an extensive edge, accomplishing speeds more than 40 mph with their Sunraycer vehicle. Because of their triumph, GM cooperated with the US Department of Energy (DOE) to hold the GM Sunrayce in 1990. The North American Solar Challenge in 2005 is held at regular intervals crosswise over various courses. In 2005, the race set another record for the longest solar vehicle race, covering 3960 km from Austin, Texas, USA to Calgary, Alberta, Canada. Notwithstanding at first being overwhelmed and supported by General Motors, the plan and development of solar vehicles has delivered its very own special improvement process. Because of the one of a kind sort of the sun based network and occasions; these advancements remain an undiscovered asset. Critical upgrades and comprehension of electric vehicles has been created that can be connected to a more extensive scope of cars to give increasingly effective and cleaner options over burning motor vehicles [2].

II. Survey Work

Solar powered controlled vehicle is a three wheel drive and has been utilized for shorter separations. The principle focus was made on enhancing the plan and making them financially savvy. Vitality from Sun is caught by the solar panels and is changed over to electrical vitality the electrical vitality consequently got is being bolstered to the batteries that get charged and is utilized to run BLDC motors. The pole of the motors is associated with the back wheel of the vehicle through chain sprocket. The batteries are at first completely charged and from there on they are charged by boards.

2.1 Paper objective

The principle goal of this undertaking is to build a solar powered electric vehicle with minimum cost to permit transport for individuals traveling a specific measure of separation each day, with essentially no expense as it will keep running off free inexhaustible solar energy. And additionally in view of fuel issue, acquainting electric vehicle is with decrease the weight on fuel and our condition will be adequate.

III. System Overview

A solar power vehicle is an electric vehicle controlled by sun powered power. This is gotten from solar panels superficially (for the most part, the best or window) of the vehicle or utilizing a solar powered coat in electric bikes. Photovoltaic (PV) cells convert the sun's vitality straightforwardly into electrical vitality. Solar powered vehicles are not sold as down to earth everyday transportation gadgets at present, however are essentially showing vehicles and designing activities, regularly supported by government offices. Anyway in a roundabout way solar powered charged vehicles are broad and solar water crafts are accessible industrially. Solar powered vehicle join innovation commonly utilized in the aviation, bike, and elective vitality and car enterprises [3]. The structure of a solar powered vehicle is seriously restricted by the measure of vitality contribution to the vehicle. Most solar autos have been worked with the end goal of sun powered vehicle races. Special cases incorporate sun powered controlled autos and utility vehicles. Solar vehicles are regularly fitted with checks as observed in traditional autos. So as to keep the vehicle running easily, the driver must watch out for these measures to spot conceivable issues. Vehicles without measures quite often highlight remote telemetry, which enables the driver's group to screen the vehicle's vitality utilization, solar vitality catch and different parameters and free the driver to focus on driving.

Solar vehicles rely upon PV cells to change over daylight into power. Indeed, 51% of daylight really enters the Earth's air. Not at all like sun based warm vitality which changes over sun oriented vitality to warm for either family unit purposes, modern purposes or to be changed over to power; PV cells specifically convert daylight into power. Whenever daylight (photons) strikes PV cells, they energize electrons and enable them to stream, making an electrical flow. PV cells are made of semiconductor materials, for example, silicon and combinations of indium, gallium and nitrogen. Silicon is the most well-known material utilized and has a proficiency rate of 15-20%. Recently, a few counseling organizations, for example, Phoenix Snider Power, have begun offering specialized and money related administrations to establishments and groups creating solar autos around the world.

There would be a great deal of segments in our vehicle, for example, Solar panel secured the entire body of the vehicle, Battery Charger, to capacity the solar power, there are 12V Lead corrosive batteries associated with the solar panels, additional 12V Lead corrosive battery for providing the advantageous power, Battery plate, BLDC motors, Voltage and Motor controller, The complete segments are appeared in the square chart.

3.1 Block Diagram:

Block diagram of the system is shown in below as fig.1 in which different components are shown used in this system as Solar Panel, Battery Storage, Battery charger, Controller, Motor (BLDC), Wheels, Brake system. External Supply is shown which is used in absence of sun light when there is no sunlight present then

we have to charge the battery with the external supply so here we are providing the external supply port in order to increase the efficiency and the betterment of the system

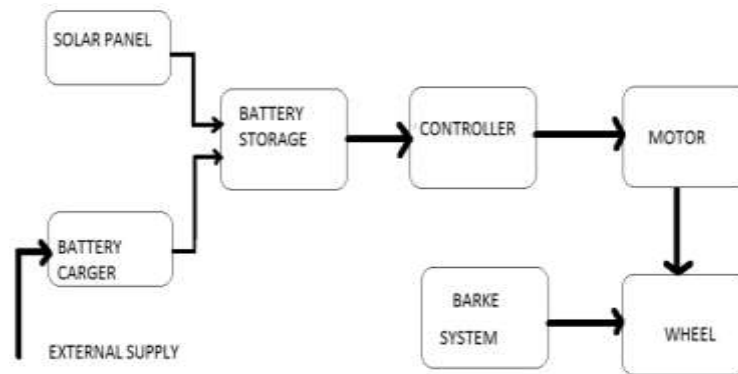

Fig1: Block Diagram

3.1.1 Solar panel:

Solar panels have been around since the nineteenth century and from that point forward till today individuals have been utilizing them for an assortment of utilizations at home, business, for transportation and notwithstanding for farming use. Solar panels are still viewed as costly On account of a sun powered vehicle, the solar panels will be a definitive provider of energy for the entire vehicle to work; in every practical sense it will be much the same as the heart that siphons blood around the human body.

3.1.1.1 Monocrystalline:

Monocrystalline silicon panels have square-formed cells and are a standout amongst the most effective sorts of solar panels. These gadgets have the most silicon content out of all the distinctive board types, which makes them increasingly costly to make however alternately takes up very less relative space. These solar panels are regularly utilized in high unwavering quality applications like broadcast communications.

3.1.1.2 Polycrystalline:

Polycrystalline silicon panels utilize less silicon, which makes them to some degree less proficient. Be that as it may, the novel structure, which highlights pieces of silicon folded over rectangular channel wires, enables them to work all the more productively. Certain incidental utilization of polycrystalline silicon solar panel, for example, when utilized on housetops can yield productivity as near as those of Monocrystalline silicon sunlight based boards

3.2 Solar system Batteries:

Solar system batteries are charged and discharged subjectively. Life time of battery is depends after charging and discharging of battery. The charging furthest reaches of the battery evaluated with Amp- hour. Battery examinations are depended by cycle. In vehicle there is used shallow cycle battery which infers battery have cycles between 10% - 15% of batteries hard and fast limit. Regardless, in solar system batteries there is used significant cycle batteries which have up to half - 80% of hard and fast battery's capacity. This kind of battery is best for sun fueled errand [3].

3.2.1 Lead-Acid Battery:

Lead corrosive batteries can be utilized in sun based vitality stockpiling. These kinds of batteries are profound cycled and possess long life energy for charging and releasing. Run of the mill life time of lead-corrosive batteries is 3-5 years. Life time of Battery really relies upon the charging and releasing cycle. Lead corrosive batteries discharges a few gas while charging. That is the reason these batteries are should have been kept outside or cross ventilated place, where air flow is adequate.

3.3 Motor selection:

As our greatest concern on designing a cost effective solar vehicle, among the two types of DC motor Brushless DC motor is most suitable for us because of its long life span, almost zero maintenance cost and high efficiency.

3.3.1 Brushless DC motor:

Brushless DC motor utilizes a pivoting perpetual magnet or delicate attractive center in the rotor, and stationary electrical magnets on the motor lodging. A motor controller changes over DC to AC. This plan is more straightforward than that of brushed motor since it takes out the intricacy of exchanging power from outside the motor to the turning rotor. Brushless DC equip motors from Oriental Motor can accomplish when joined with a standard equipped alternative [4]. Their space sparing structure adds to a smaller and amazing arrangement extending from 15 W up to 400 W. Their level torque attributes can create the equivalent appraised torque at wide speed extend. Brushless DC Motors (BLDC Motors) likewise highlight a wide assortment of pre amassed equipped and electromechanical brake choices and are accessible with our industry driving stable lead times.

3.3.2 Construction:

Construction of BLDC motor as shown in fig.2 the brushless DC outfit motor includes a loop is star-wired (Y-wired) with three-stages: U, V, and W and is situated in the stator, and the rotor is made of magnets charged in a multi-post arrangement as appeared in fig 2.

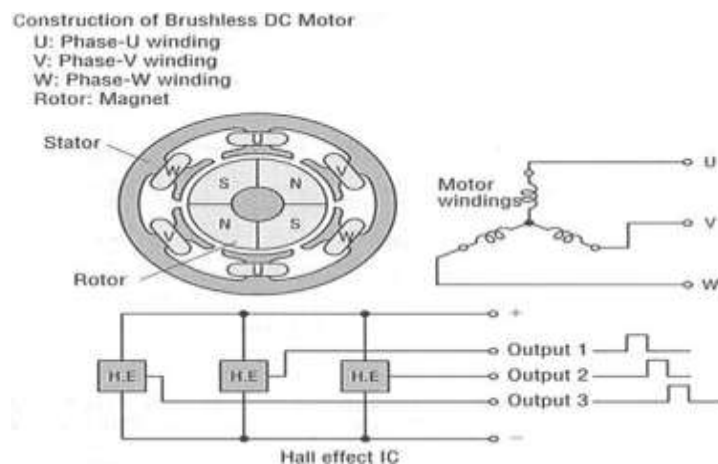

Fig2: Construction of BLDC Motor

From fig.2 inside the stator, three porch ICs are organized as attractive components with the area that the stage distinction of the yield wave from every passage IC will be 120 degrees separated for each revolution of the rotor. Brushless DC Motors (BLDC Motors) are very compact and when mated with a gear head, can produce a large amount of torque. The Brushless DC Motors (BLDC Motors) do not use brushes, which frequently require swapping and/or maintenance, saving time and cost.

IV. Problem Identification

From the earliest starting point of our undertaking work we are centered around diminishing weight on oil just as not presenting electric vehicle since it will make an additional heap to our national network. To present solar powered vehicle we confront four noteworthy issues and these are providing power around evening time, charging sun based board in terrible climate condition, planning the controller and most huge isn't getting adequate measure of vitality from solar panel. These prime difficulties coming in our direction are portrayed quickly here [5].

4.1 Power supply at night:

The best issue with solar panels is it can't supply control if there is no sun beam falling on the solar panels. So on the off chance that anybody needs control supply from solar panels when there is no daylight he should have capacity the additional energy to another gadget (battery) appended to the framework. Two batteries consistently store the electric vitality originating from the solar panels and supply that vitality to stack when required. So the framework should have two batteries associated with solar panels to guarantee steady power supply in the motor.

4.2 Charging at night and bad weather condition:

At the point when there is overwhelming mists for a few back to back days in blustery seasons. This overcast condition may mischief to deliver adequate measure of vitality to run the vehicle. So that on that times both the batteries can't charge completely and supply vitality to motor.

4.3 Solar panel cannot supply whole day’s energy:

The motor used in the vehicle need high amount of power whole the day but the outer space of the vehicle covered by solar panel is not supply that amount of power constantly because it store energy to battery in a low rate and not all the time sunlight hit the solar panel in same way. So connecting both batteries with solar panel is ideal because when one battery is in full charge then other battery will store energy from solar panel.

V. Methodology

5.1 Design Analysis:

5.1.1 Motor power rating:

Solar powered vehicle contrasted with interior burning motor vehicles are less difficult in that they have few noteworthy segments. Be that as it may, being an electrical framework makes exact computations of the appraisals of these significant segments of the vehicle basic at the plan arrange. The appraisals of the 3 noteworthy segments of the vehicle that will be resolved are

- 1) The motor control rating required to accomplish the fundamental speed and increasing speed.
- 2) The battery limit which can bolster the separation required to be voyage.
- 3) The solar panel details expected to keep the battery adequately charged for the voyage.

The power rating of the motor will decide the battery limit for example Ampere-hour charge and voltage expected to conquer the most extreme separation that the solar powered vehicle will go on sunlight based power alone. Therefore this thus will decide the board wattage required to support the battery charge [6].

5.1.2The rolling resistance:

The moving opposition compel is the power opposing the moving movement of the tires as they move over the street surface. Variables that add to moving opposition are the (measure of) misshaping of the wheels, the distortion of the roadbed surface, and development beneath the surface. Extra contributing elements incorporate wheel distance across, speed, load on wheels and so on. For instance, an elastic tire will have higher moving opposition on a cleared street than a steel railroad wheel on a steel rail. Thus, sand on the ground will give more moving opposition than cement. The moving obstruction power can be communicated as,

$$F_{rolling} = \mu R * W \dots\dots\dots [1]$$

Where, W is the weight of the vehicle

μR is the coefficient of rolling resistance

What’s more, is a consistent that relies upon the sort of feels worn out on the vehicle and the surface on which it will roll. Thicker tires with more extensive tracks, albeit useful for bond, anyway create additionally moving obstruction. To monitor control sun based autos need to utilize more slender tires. Likewise harder surfaces offer lower moving obstruction compel than milder ones. Some standard qualities are appeared as pursues.

Table1: coefficient of rolling resistance μR of different wheels/surface

0.0003-0.0004	Rolling resistance Railroad steel wheel on steel rail
0.0010-0.0024	Passenger rail car about 0.0020 Railroad steel wheel on steel rail.
0.001-0.0015	Hardened steel ball bearings on steel
0.0045 to 0.008	Large truck (Semi) tires
0.010 to 0.0015	Ordinary car tires on concrete
0.3	Ordinary car tires on sand
0.0385 to 0.073	Stage coach (19th century) on dirt road. Soft snow on road for worst case.
0.0022-0.005	Production bicycle tires at 120 psi (8.3 bar) and 50 km/h (31 mph), measured on rollers

$$F_{rolling} = \mu R * GVM$$

$$\mu R = 0.005 \dots\dots\dots \text{(From above table)}$$

$$GVM = 500 \quad \text{(with load)}$$

$$F_{rolling} = 0.005 * 500 = 2.5 \text{ N}$$

5.3 Aerodynamic drag force:

The streamlined drag force is just the power applied by the air to keep the vehicle from traveling through it. The streamlined drag power can be communicated

$$F_{drag} = [(1/2) * cD * A_{cross} * \rho * (V)^2] \dots\dots\dots [2]$$

Where, cD is the coefficient of drag of the vehicle

A_{cross} is its frontal area in square feet

ρ is a constant that stands for the air mass density

V is the vehicle’s speed

To minimize drag for any given C_d , the coefficient of drag, and across, and its frontal area must be minimized. Fig.3 shows coefficient of drag. The drag constrains turns out to be progressively discernible at rates of over 40 km/h because of it being relative to the square of the speed. Since batteries give just 1% as much power per load as gas, enhancing for either fast or long-run execution objectives, necessitates that one remembers this basic execution factor first. As it is observable from figure the more streamlined the state of the vehicle the lower is C_d . It is assessed that for ordinary vehicle structures, the body's back zone contributes over 33% of C_d without anyone else's input, trailed by the wheel wells at 2%, the underbody zone at 14%, the front body territory at 12%, projections(minors, dribble rails, window breaks and so forth.) at 7%, and motor compartment and skin grating at 6% each.

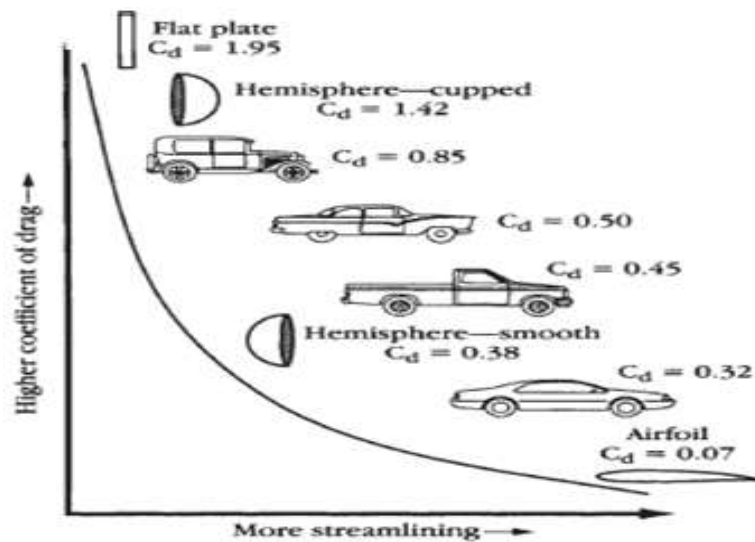

Fig3: Coefficient of drag of different vehicle shapes

$$F_{drag} = [(1/2) * C_d * A_{cross} * \rho * (V)^2]$$

$C_d = 0.85$ (From fig.3)

The frontal area side in inches is 40 inch & 31 inch. It converts in cm & m.

40 inch = 101.6 cm = 1.016 m

31 inch = 78.74 cm = 0.7874 m

Then, $A_{cross} = 1.016 * 0.7874 = 0.8 \text{ m}^2$

$\rho = 1.225 \text{ Kg/m}^3$

$V = 6.94$

$$F_{drag} = [(1/2) * 0.85 * 0.8 * 1.225 * (6.94)^2]$$

$$F_{drag} = 2.89 \text{ N}$$

5.4 Force of acceleration:

The power of increasing speed ought to be represented when the vehicle is quickening and is given by newton's second law of movement

$$F_{acceleration} = [m * a] \dots \dots \dots [3]$$

but $m = GVM / g$

$GVM =$ Gross Vehicle Weight of the vehicle

Where,

$a =$ required acceleration.

$m =$ mass of the vehicle

$g =$ acceleration due to gravity ($9.81/\text{se}^2$)

$$m = 500 / 9.81 = 50.96$$

$$a = dv/dt = (v_f - v_i) / (t_f - t_i) = (35-0) / (10-0) = 3.5 \text{ m/s}^2$$

$v_i =$ Initial Speed $t_i =$ Initial Time $v_f =$ Final Speed $t_f =$ Final Time

$$F_{acceleration} = [50.96 * 3.5] = 178.36$$

The total driving force thus required to overcome the sum of these opposing forces to move the vehicle is,

$$F_T = F_{rolling} + F_{drag} + F_{acceleration}$$

$$= [\mu R * GVM] + [(1/2) * C_d * A_{cross} * \rho * (V)^2] + [m * a]$$

$$= [2.5 + 2.89 + 178.36]$$

$$= 183.75 \text{ N/m.}$$

5.5 Torque:

$$\text{Torque} = R_f * F_T * r \dots \dots \dots [4]$$

$R_f =$ Friction factor that account for frictional losses between bearings, axles etc

The frictional losses among the wheels and their axles and the effort on the motor bearings. Classic values choice between 1.1 and 1.15 (or 10 to 15%). [8]

R = radius of drive wheel (m)

$$\begin{aligned} \text{Torque} &= R_f * F_T * r \\ &= 1.1 * 183.75 * 0.20 \\ &= 40.425 \text{ N/m.} \end{aligned}$$

VI. Project Implementation

6.1 Controller:

BLDC Controller Circuits have PWM chopper control which helps in controlling the PWM obligation cycle. It depends on simple information (8-bit ADC) and ensures the continuous execution of the circuit. Designed utilizing best accessible methods, this give exact planning which permits to precise speed and torque control, and furthermore ensure its pinnacle effectiveness. The application explicit plan and high practical productivity of these gadgets helps in beginning forward and turn around pivot and motor brake work for steady execution. These circuits bolster quicker powerful reaction with silent task and higher speed goes. Brushless DC motor frameworks are accessible with electronic-input control. The driver can be associated straightforwardly to a programmable controller. As the motor requires no power transfers, there is no requirement for occasional administration or substitution of transfers. This makes the machine exceedingly solid. In addition, the time required to set up the motor is incredibly diminished. Evacuating the transfers kills the start commotion amid opening and shutting of the hand-off contact focuses.

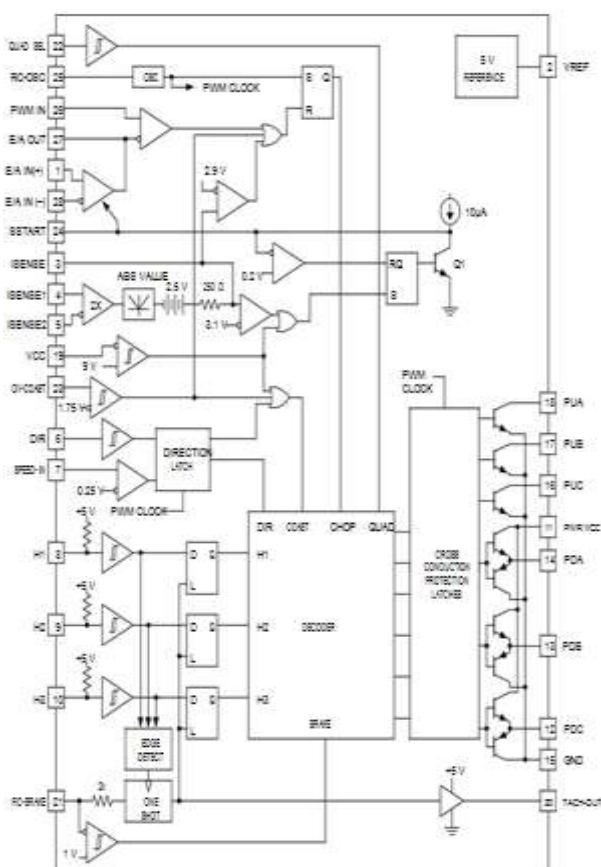

Fig4: Controller Layout

The motor controller layout shown in fig.4 incorporates the majority of the capacities required for elite brushless dc motor control into one bundle. At the point when combined with outer power MOSFETs or Darlington, this gadget performs settled recurrence PWM motor control in either voltage or current mode while executing shut circle speed control and braking with savvy clamor dismissal, safe heading inversion, and cross-conduction assurance. Albeit determined for task from power supplies between 10 V and 18 V, 26 V, 48 V the controller can control higher voltage control gadgets with outer dimension moving parts. The controller contains quick, high-ebb and flow push-pull drivers for low-side power gadgets and 50-V open-gatherer yields for high-

side power gadgets or level moving hardware. The controller is described for task over the temperature scope of -55°C to 125°C [7][8].

Description

- i. Rated voltage: 48 v DC
- ii. Current limit: 50A
- iii. Rated power: 900 w
- iv. Matching motor: dc brushless motor

6.2 Chassis and mechanical system:

Fig.5 shown above is the actual view of the chassis. The shape of the bodywork determines the aerodynamic drag, which above 25 mph can rise significantly. In the project we are working by a fixed solar panel on the top of the vehicle. Another consideration is weight and stiffness. To make the vehicle light in weight the body material should be as light as possible. On the other hand the material should be enough stiffer to carry the load [9].



Fig5: Screen Shot of Chassis

6.3 Steering:

Steering of a vehicle is shown in fig.6 utilized for controlling heading of the vehicle. It really moves both front wheels in an equivalent point when the vehicle alters its course. Controlling framework (manual directing framework) was utilized for this solar vehicle venture. Manual directing is an old guiding framework and today is as yet utilized as a result of its minimal effort. A level rack adapts moves inside the rack body and it is driven by pinion. Pinion is a round rigging. The directing wheel is associated with the pole of the vehicle.



Fig6: Screen Shot of Steering Mechanism

The rack adapt is associated with a pole that is hanging inside and it is secured by an elastic cover beneath. The external piece of the inward attach pole is associated with the external piece of the external tie bar. These poles have some unique highlights state for instance these bar closures can move any straight way. At the very end the tie bar end is associated with the axle of the wheel.

6.4 Transmission system:

The differential shown in fig.7 is a gadget that parts the motor torque two different ways, permitting each output to turn at an alternate speed. The differential is found on every cutting edge vehicle and trucks, and furthermore in some all-wheel-drive (full-time four-wheel-drive) vehicles.



Fig.7: Screen Shot of Actual Differential

These all-wheel-drive vehicles require a differential between each arrangement of drive wheels, and they require one between the front and the back wheels also, in light of the fact that the front wheels travel an alternate separation through a turn than the back wheels [10].

6.5 Braking system:

The term drum brake as a rule implies a brake in which shoes push on the internal surface of the drum. At the point when shoes push outwardly of the drum, it is typically called a fasten brake. Where the drum is squeezed between two shoes, like a regular plate brake, it is here and there called a squeeze drum brake; however such brakes are moderately uncommon.

There is a switch associated with the stack agent in the back haggle the brake pedal. Break paddle is associated with another switch and a spring. At the point when the brake pedal is squeezed the switch appended to it is pulled and it endeavors to push ahead and subsequently the switch associated with the stack agent attempts to move in forward. At the point when the switch pushes ahead the stack agent spring gets a weight from it and it endeavors to move the clockwise way. Subsequently it puts weight on the break shoe. Because of this weight break shoe attempts to extend the outward way and as it is associated with the back wheel center point, the vehicle in the long run stops. This is fundamentally how the slowing mechanism functions [10][11].

VIII. Conclusion

Request of fuel is expanding step by step. To satisfy the interest of this expanding fuel request it's a great opportunity to search for exchange sources. Solar energy is by a long shot the best decision since it is modest, condition well-disposed and in particular it is provided by an everlasting wellspring of energy. The extent of the task includes structuring and building a proto-type sun powered fueled clean vehicle that would be conservative, dependable and ecologically well disposed. The skeleton of the vehicle is built with key parts, for example, suspension framework, Brake mechanism, Steering, all set up. At long last a streamlined external body shape is proposed. Obviously it is particularly cost effective and the plan of body of this vehicle is finished by less weight material as contrast with the other vehicle accessible before this vehicle. This is only the start of another innovation venture began and it is ensured that future advancements will make sun powered vehicles the dominating method of transportation over vehicles with interior ignition motors.

References

- [1]. Md. Muntashir Bin Mahfuz, Md Tahsin-ul-Islam, Design a solar powered clean car, Report submitted to dept. of Electrical and Electronics Engineering of Brac university April 2012.
- [2]. U. S Department of Energy. A Consumer's Guide: Get your Power from the Sun Energy Efficiency and Renewable Energy, U.S Department of Energy.
- [3]. Md. Jobair Bin Alam, Traffic induced noise pollution in Dhaka city, published on Journal of Civil Engineering, The Institution of Engineers, Bangladesh, Vol. CE 29, no. 1, 2001
- [4]. Vasilis M. Fthenakis, Hyung Chul Kim, and Erik Alsema. Emissions from Photovoltaic Life Cycles Environ. Sci. Technol
- [5]. Adinolfi G., Arsie I., Di Martino R., Giustiniani A, Petrone G., Rizzo Sorrentino M.(2008) , A Prototype of Hybrid Solar Vehicle: Simulations and On-Board Measurements, Proc. of Advanced Vehicle Control Symposium AVEC 2008, October 6-9, 2008, Kobe, (Japan) 917-922 Society of Automotive Engineers of Japan - ISBN: 978-z 904056-21-9
- [6]. Design and Fabrication of a Solar Powered Car Conference Paper · April 2014 DOI:10.1109/ICEEICT.2014.6919041

- [7]. Mubarak W. Al-Grafi , Mostafa K. Mohamed and Farhan A. Salem Analysis of Vehicle Friction Coefficient by Simulink/Matlab, Taibah University, College of Engineering, Al-Madinah Al-Mounwara, Saudi Arabia.Taif University, Faculty of Engineering, Mechanical Engineering., Saudi Arabia International Journal Of Control, Automation And Systems Vol.2 No.2 July 2013
- [8]. EML2322L – MAE Design and Manufacturing Laboratory Drive Wheel Motor Torque Calculations Reference Citation: White Hydraulics Drive Products
- [9]. Daniels M W and Kumar P R (2005), The Optimal Use of the Solar Power Automobile, Control Systems Magazine, IEEE, Vol. 19, No. 3.
- [10]. John Connors Solar Vehicles and Benefits of the Technology, ICCEP Paper(2007)
- [11]. Gianfranco Rizzo, Ivan Arsie, and Marco Sorrentino,Solar energy for cars: perspectives, opportunities and problems,GTAA Meeting, Mulhouse, 26-27 May, 2010